

TERMINAL BLOCK

TRT-159-9P (M3.5)

WIRING DIAGRAM

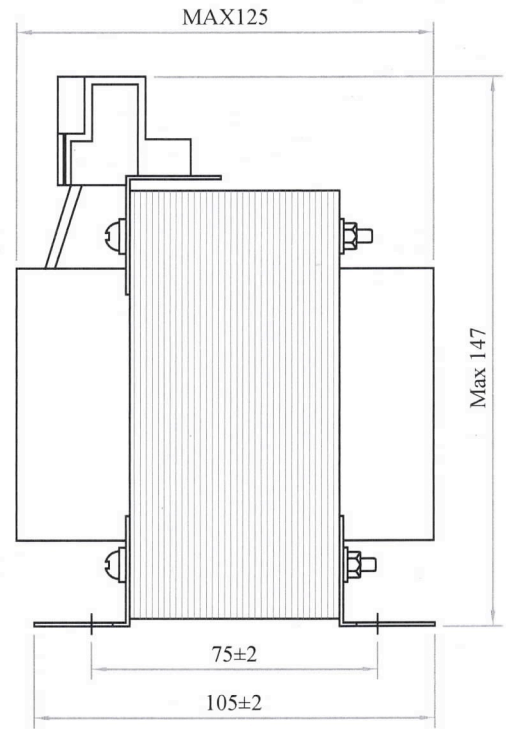
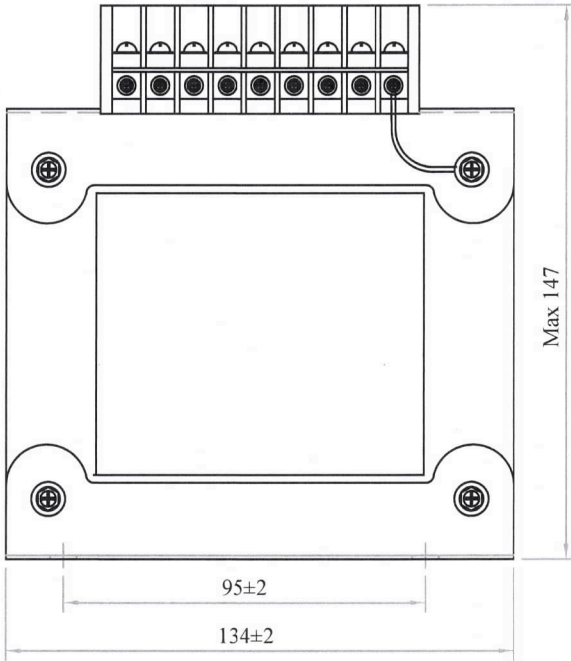
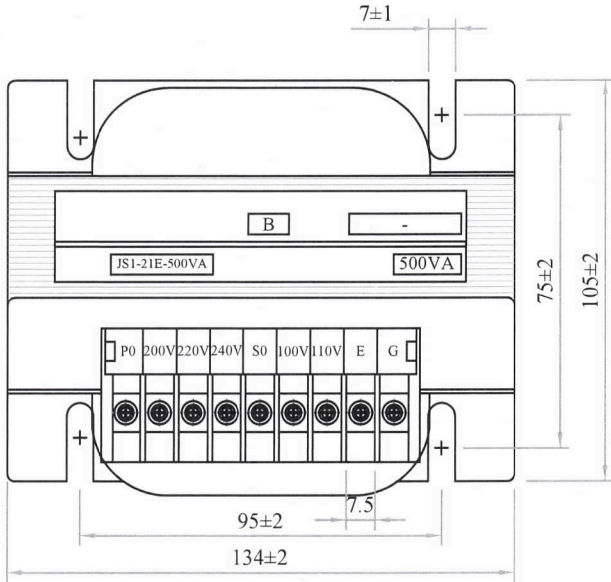
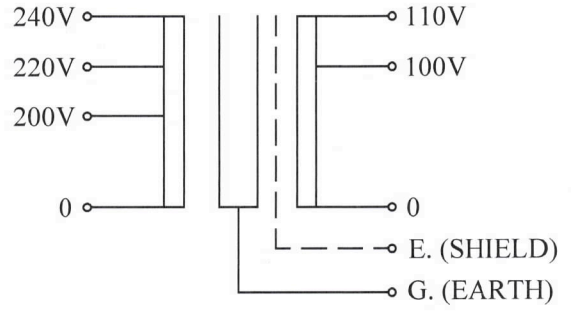

PHASE / CAPACITY	1Ø 500VA
FREQUENCY	50/60Hz
PRIMARY VOLTAGE	200V-220V-240V
SECONDARY VOLTAGE	100-110V
SECONDARY CURRENT	5.0A(100V)
INSULATION CLASS	" B "
WEIGHT	7.5 Kg.

GENERAL TOLERANCE

0-200 ±2 MORE THAN 201 ±3

CHEKED	DESIGN	DRAWN	SCALE	APPROVAL
ITEM.	1Ø 500VA ISOLATION TRANSFORMER			
ITEM No.	-			
DRA. No.	JS1-21E-500VA			
CLIENT	-			
DRAWN	SDS ASIA CO., LTD.			

SYM	REVISION RECORD	DATE	DRAWN
4		3	